



VISION Rechargeable Products
Sealed Lead Acid Battery

www.vision-batt.com

UNA Series

High Rate Discharge

The new VISION UNA series batteries are specially designed for applications where need high power output. By optimum design of battery grids and plate paste formula, the UNA series can deliver up to 40% more power than VISION standard CP/FM series.

Shenzhen Center Power Tech Co., Ltd has more than 20 year's experience in the manufacturing of VRLA batteries.

SZCPT is one of the largest manufacturers of SLA (or VRLA) batteries in the world, the largest one in Mainland China and the first in China to develop and commercialize the sealed lead-acid battery with brand name VISION and has been at the forefront of battery technology from day one.

SZCPT leads the world in innovative battery technology. Our global network of sales and service engineers, backed in turn by our agents and distributors, means that we are currently active in more than 100 countries.

Shenzhen Center Power Tech. Co., Ltd

UNA12-200 12V 200W

(Edition 2014-9)

General Features

- Positive and negative plates in lead-calcium tinalloy
- Superior energy density
- Operates at a low internal pressure.
- Gas Recombination
- Usable in any orientation
- A recognized component of UL
- Very high power output
- Application specific designs
- A couple Range from 90W to 540W per cell for 15' @ 1.67Vpc
- Six months shelf life at 20°C
- Design life 10 years



Dimensions and Weight

	Metric Units	English Units
Length	229mm	9.02inch
Width	138mm	5.43inch
Height	208mm	8.19inch
Total Height	213mm	8.39inch
Approx. Weight	17.0Kg	37.5lbs

Performance Characteristics

- Nominal Voltage 12V
- Number of cell 6
- Nominal Capacity 77 °F(25°C)
 - 15 min wattage @1.67V 200W/cell
 - 10 hour rate (5.50A, 10.8V) 55.0Ah
- Torque setting: 8.5NM
- Internal Resistance
 - Fully Charged battery 77°F(25°C) ≤ 6.0mOhms
- Self-Discharge
 - 3% of capacity declined per month at 20°C(average)
- Operating Temperature Range
 - Discharge -20~60°C
 - Charge -10~60°C
 - Storage -20~60°C
- Max. Discharge Current 77°F(25°C) 550A(5s)
- Charge Methods: Constant Voltage Charge 77°F(25°C)
 - Cycle use 2.40-2.45VPC
 - Maximum charging current 16.5A
 - Temperature compensation -30mV/°C
- Standby use 2.20-2.30VPC
 - Temperature compensation -20mV/°C



Center Power Industrial Park, Tongfu Industrial District Dapeng Town, 518120 Shenzhen, China
Tel: 86 755 84318088 Fax: 86 755 84318038 E-mail: sales@vision-batt.com
Website: <http://www.vision-batt.com>

UNA12-200 12V 200W

Discharge Data

Constant Current Discharge Data (Ampere at 25 °C)

End Voltage Volts/Cell	5min	10min	15min	20min	30min	40min	50min	60min
1.60	236	159	119	96.0	69.8	56.0	47.1	40.6
1.67	212	152	115	94.2	69.1	55.2	46.6	40.0
1.70	203	147	113	92.9	68.3	55.0	46.4	39.9
1.75	186	137	108	89.3	66.2	53.6	45.5	39.1
1.80	160	122	99.0	82.7	62.7	51.7	43.7	37.8

Constant Power Discharge Data (Watts at 25 °C)

End Voltage Volts/Cell	5min	10min	15min	20min	30min	40min	50min	60min
1.60	374	267	204	168	125	101	85.0	72.8
1.67	353	255	200	166	124	100	84.7	72.6
1.70	337	248	196	163	122	99.1	84.6	72.5
1.75	309	233	188	157	118	97.6	82.9	70.9
1.80	281	215	177	147	113	94.2	79.8	69.1

(Note)The above characteristics data are average values obtained within three charge/discharge cycles not the minimum values.
All data shall be changed without notice,Vision reserves the right to explain and update the information contained hereinto.

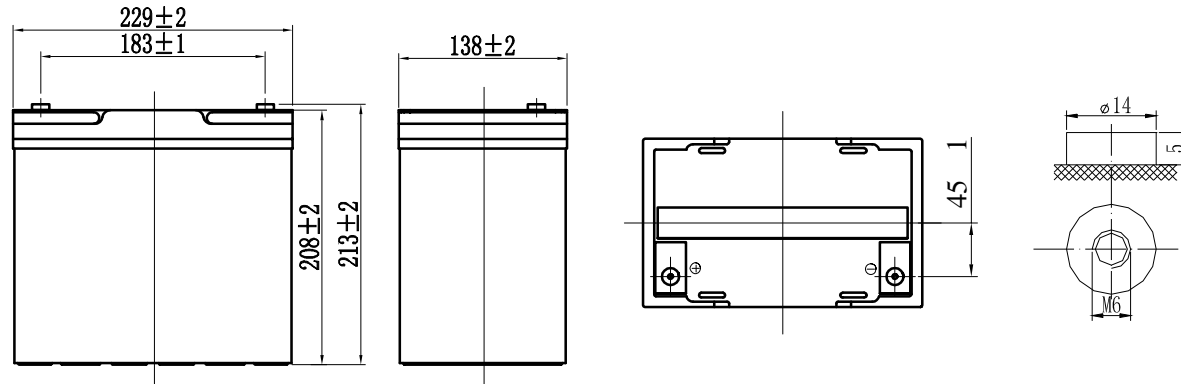

UNA12-200 12V 200W

